

(No Model.)

H. J. EISEN.

ART OF MAKING DUPLEX ESCAPEMENT WHEELS.

No. 515,861.

Patented Mar. 6, 1894.

Fig. 1.

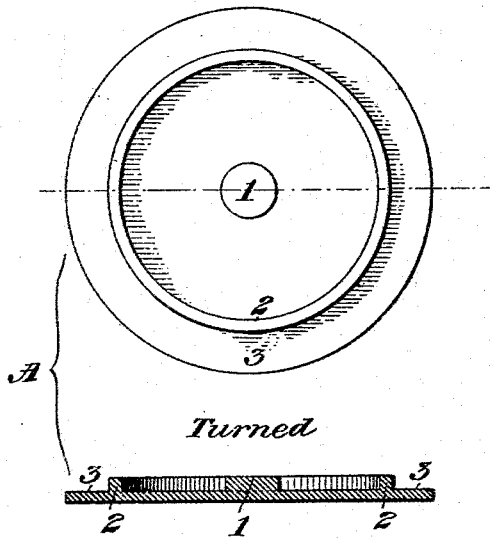

Fig. 2.

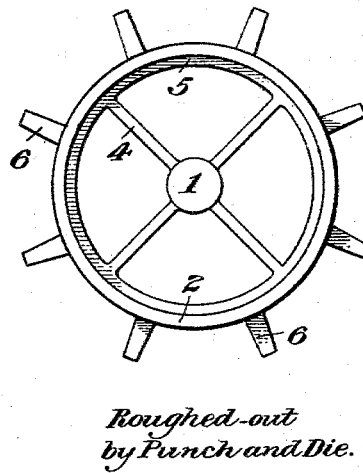

Fig. 3.

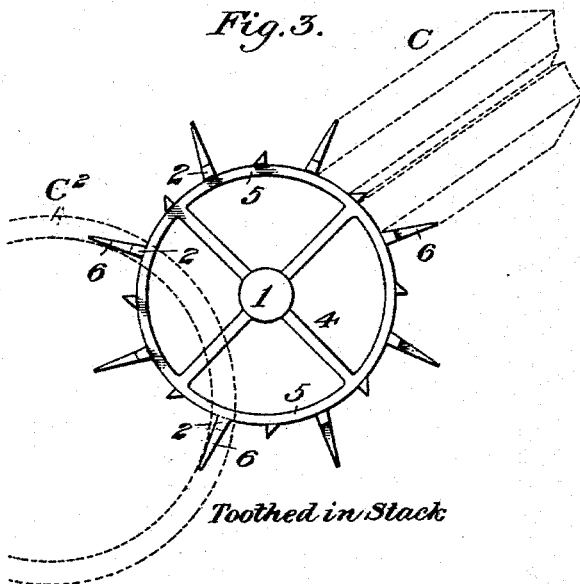
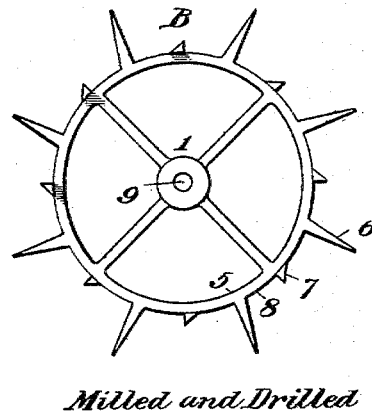

Fig. 4.



Witnesses

T. A. Comer  
Geo. M. Whitney

Inventor

Herman Joseph Eisen  
by M. L. Swin  
Attorney

# UNITED STATES PATENT OFFICE.

HERMAN JOSEPH EISEN, OF BROOKLYN, NEW YORK, ASSIGNOR TO EDWARD  
A. LOCKE, OF BROOKLINE, MASSACHUSETTS.

## ART OF MAKING DUPLEX ESCAPEMENT-WHEELS.

SPECIFICATION forming part of Letters Patent No. 515,861, dated March 6, 1894.

Application filed June 28, 1893. Serial No. 479,067. (No model.)

*To all whom it may concern:*

Be it known that I, HERMAN JOSEPH EISEN, a citizen of the United States of America, and a resident of Brooklyn, in the State of New York, have invented a new and useful Improvement in the Art of Making Duplex Escapement-Wheels, of which the following is a specification.

Heretofore the "scape-wheels" of all duplex escapements, except those the teeth of which are laboriously shaped one by one by hand, have of necessity been made of soft brass, so as to provide for die-forming the "impulse teeth" or for bending them to bring them into their different planes as compared with the spur teeth or "long teeth." Consequently such scape-wheels have had to be made comparatively heavy and of excessive inertia in order that the delicate long teeth might resist their contacts with the balance-arbor, and are peculiarly liable to become bent in the hands of watch-makers so as to become inoperative.

The present invention consists in a novel process whereby superior scape-wheels of shape-preserving hard metal and of light weight may be manufactured exclusively by machinery, and in a certain novel portion of said process, as hereinafter set forth and claimed.

A sheet of drawings accompanies this specification as part thereof.

Figure 1 of the drawings comprises a face view and a diametric section of a circular blank produced by lathe-turning, illustrating the first stage of said process. Fig. 2 is a face view illustrating its second stage. Fig. 3 is a face view, with appended representations of milling cutters, in dotted lines, illustrating the third and fourth stages of the process; and Fig. 4 is a face view of the finished product.

Like letters and numbers refer to like parts in all the figures.

The blank A, Fig. 1, is produced by lathe-turning, and consists of a flat circular disk having a central hub-projection 1 and a concentric annular flange 2, preferably on one and the same side of the body of the disk, which extends beyond said annular flange in

the form of a wide margin 3. The blank is next passed to a punch and die of the pattern indicated by Fig. 2, which represents their product. The blank as thus "roughed out" has the spokes or "cross" 4 of the final product B, Fig. 4, together with its rim 5, except the peripheral surfaces of the latter, and also the long teeth 6 in rough; the latter being formed from said margin 3 Fig. 1, by removing the interdental portions thereof, while said cross and rim are formed by punching out portions of the body of the disk, Fig. 1, between said hub projection 1 and annular flange 2. The latter are left untouched by the punch and die. A number of the roughed out blanks, Fig. 2, are next assembled in a "stack," and subjected to the action of one or more suitable milling cutters C, Fig. 3, by which the long teeth 6 are shaped as to their lateral edges, and the intermediate impulse teeth 7 are formed or completed at one and the same progressive milling operation; said impulse teeth being cut from that portion of the blank Fig. 1 which is provided with said annular flange 2, so as to project above the plane of said long teeth to a second plane, as required in duplex escapements, without any displacement of the metal of the teeth. Functionless portions of said annular flange 2 remain on the long teeth 6, as at 2 in Fig. 3. To remove these portions, each scape-wheel is next subjected to the action of an annular milling cutter, C<sup>2</sup>, Fig. 3. This cutter removes said functionless portions of the flange 2, from two of the long teeth 6 simultaneously, as illustrated in Fig. 3, and thus rapidly completes the teeth of the scape-wheel. The bore 9 Fig. 4 of its hub 1 is next drilled, which completes the final product, as represented by Fig. 4.

The product is distinguished from other machine-made scape-wheels for duplex escapements in that it is of light weight and of hard metal as aforesaid, and furthermore by having impulse teeth which project bodily from the periphery of the rim of the wheel and extend upward to a plane above that of the long teeth by being of extra thickness or width from bottom to top. The scape-wheel may be thus made with a greater or less num-

55

50

65

70

75

80

85

90

95

100

ber of teeth as preferred, and other like modifications will suggest themselves to those skilled in the art.

I do not claim herein the aforesaid product of my process of manufacture, but claim the same in another specification of even date herewith, in favor of which it is hereby disclaimed. I refer to my specification forming part of an application for patent, filed June 28, 1893, Serial No. 479,068.

Having thus described the said improvement, I claim as my invention and desire to patent under this specification—

1. The method of making hard-metal scape-wheels for duplex escapements which consists in providing a blank with a hub-projection an annular flange and a wide margin external to said flange by turning, producing the cross and rim, except as regards the peripheral surfaces of the latter, and also roughing

out the long teeth, by a punching operation, cutting all the teeth in the stack by cuts extending inward through said flange, milling off the functionless remnants of said flange, and finally drilling the hub, substantially as hereinbefore specified.

2. In making scape-wheels for duplex escapements, the method of forming the teeth which consists in providing the blank with an annular flange and a wide margin external to said flange by a turning operation, roughing out the long teeth from said margin by punching, and cutting all the teeth in the stack by cuts extending inward through said flange, substantially as hereinbefore specified.

HERMAN JOSEPH EISEN.

Witnesses:

THOS. D. RAMBAUT,  
ALEX. LEHMAN.